

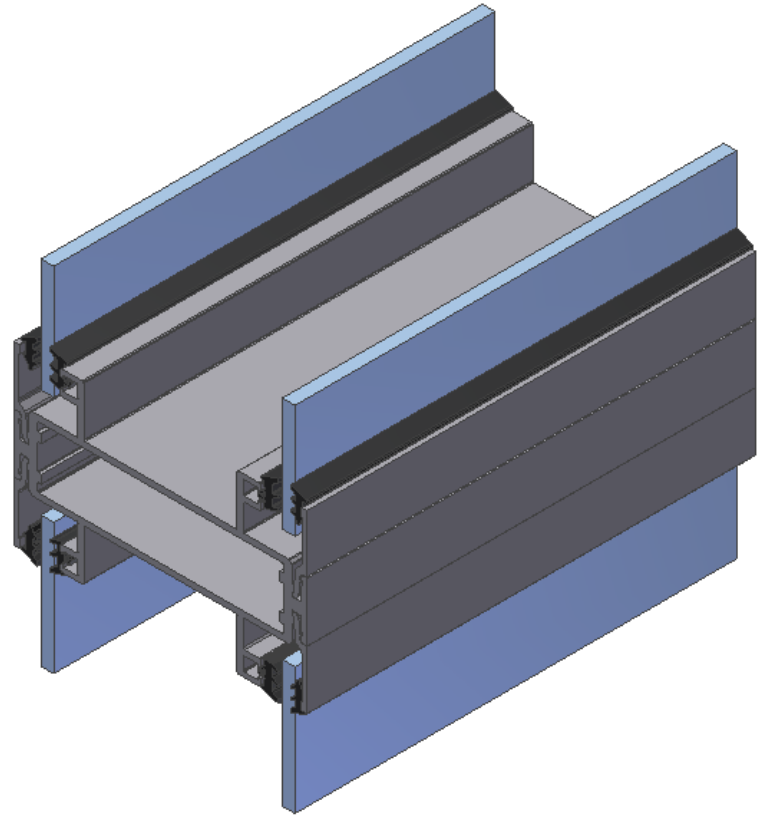

Standard Options

- Best sound ratings for interior partitions
- Flushed glazed
- Framing systems include extrusions of 2-3/8" x 4"
- Two glazing at 1/4 to 3/8"
- Glazed in center of frame with roll-in EPDM gasket
- Two different assembly options:
 1. Shear Block
 2. Corners reinforced with corner cleats and mechanically crimped
- Multiple corner post configurations
- Adjustable and 135° mullion



Optional Features

- Extrusion are of aluminum alloy: 6005, 6060, 6463, 6063
 - Wall thickness 1/8"
- Wood panels, metal panels, decorative panels can be used
- Door framing components
- Wood and frameless glass doors available
- Concealed hinges
- Internal blinds between glass
- Sidelite bases to match door bottom rails
- Anodized and painted finishes
- 220 color options

Made in the USA



Performance

Design Pressure +/- 50 psf
 Air Infiltration..... <0.01cfm/ft²

Water Test Pressure..... 10 psf
 Uniform Load Structural -/+90 psf

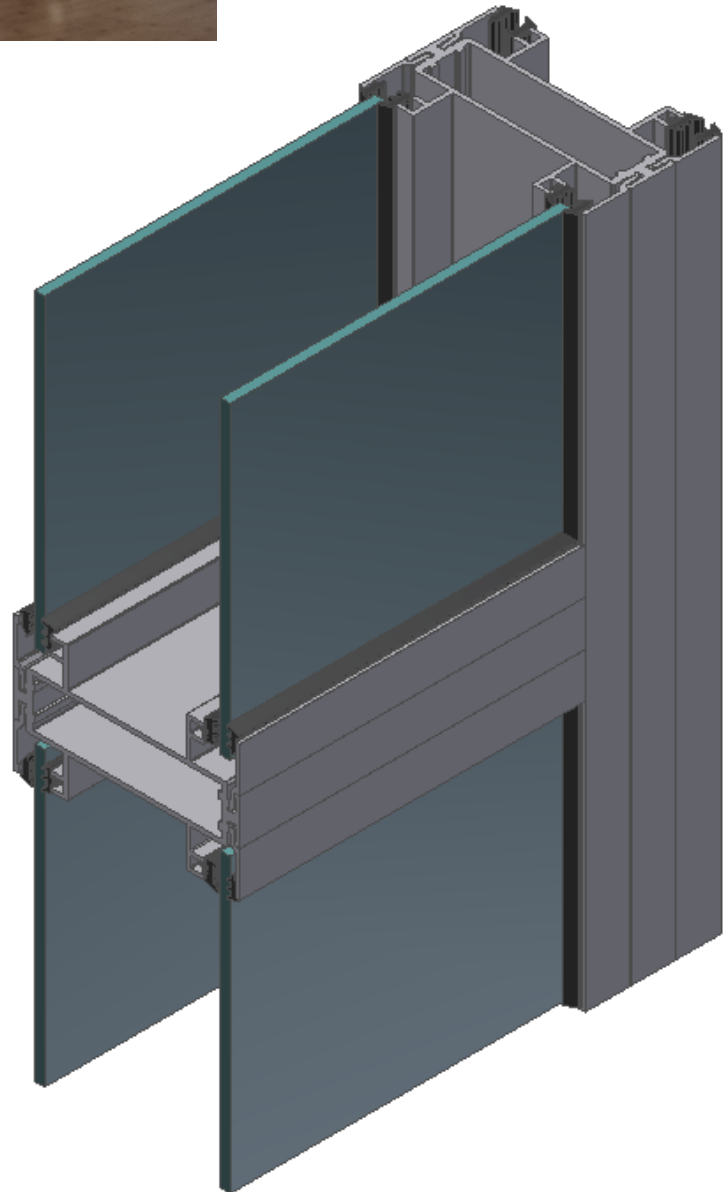



Horizontal Cross Section View

